



Fall
Home
Show
2019

2019 Exhibitor's Guide

October 4-6

PRESENTED BY:



General Information

Location: **TRAC** 6600 Burden Blvd, Pasco, WA

Show Dates & Times: Friday, Oct. 4 ~ 10am - 6pm
Saturday, Oct. 5 ~ 10am - 6pm
Sunday, Oct. 6 ~ 10am - 4pm

Set Up: Thursday, Oct. 3 8 am - 8 pm

Take Down: Sunday, Oct. 6 4 pm - 9 pm

Exhibit Space Pricing:

10' x 10' Linear Exhibit.	\$500
10' x 10' Unlimited Exhibit	\$500
10' x 10' Corner Exhibit.	\$600
10' x 10' Unlimited Corner Exhibit. . . .	\$600

Prices include draped panels (3' side/8' rear), 120 volt (500 watts/5 amp) receptacle per Exhibitor and three Exhibitor passes, which are not transferable.

Vehicle and Outside Exhibit Pricing:

Contact the HBA for pricing information and layout of limited exhibit space in the entry and front of the TRAC facility.

Discounts:

- \$100 per exhibit space for all current HBA of Tri-Cities members.
- \$50 per exhibit space Early Bird Discount on booths reserved (deposit & agreement received) by July 31, 2019.

Please complete agreement form and mail to:

Home Builders Association of Tri-Cities
10001 W. Clearwater Ave.
Kennewick, WA 99336

Or fax to:
509.735.8470

Or email to:
heather@hbatc.com

Booths will NOT be reserved until completed agreement and deposit are received.

Exhibit Guidelines

Regardless of the number of Linear Exhibit spaces utilized, display materials must be arranged in such a manner so as not to obstruct sight lines of neighboring exhibitors.

Linear Exhibit

A Linear Exhibit has only one side exposed to an aisle. The maximum finished height of eight feet (8') is allowed only in the rear half of the exhibit space. Signage is allowed up to twelve feet (12'). Signs bordering another exhibit space must be one-sided and face inward. A four foot (4') height restriction is imposed on all materials in the remaining space forward to the aisle. Three-foot curtained side rails are provided for each exhibit space. When three or more adjacent Linear Exhibits are utilized by the same exhibitor as a single exhibit space, the four foot (4') height limitation is applied only to that portion of the exhibit space which is within 5 feet (5') of an adjoining exhibit.

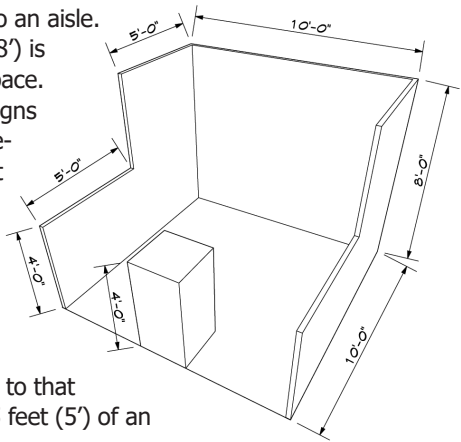

Unlimited Exhibit

An Unlimited Exhibit is not required to follow the Exhibit Guidelines outlined in this brochure except that signs bordering another exhibit space must be one-sided and face inward. Pop-up tents with branding on all 4 sides are exempt from signage rules and are only allowed in the Unlimited rows. However, pop-up tent side panels can only be used on the rear of the tent. Unlimited Exhibits can only be found in rows E, H, I, J, K, P, Q or R.

Corner Exhibit

A Corner Exhibit is a Linear Exhibit except that it is exposed to aisles on two sides. All other guidelines for Linear Exhibits apply.

End-Cap Exhibit

An End-Cap Exhibit is exposed to aisles on three sides and composed of two, four, or six 10' x 10' exhibit spaces. The back wall height of eight feet (8'), with signage to twelve feet (12'), is allowed only in the rear half of the exhibit space and must be at least five feet (5') from each of the two side aisles with a four foot (4') height restriction imposed on all materials in the remaining space within five (5') of the aisle.

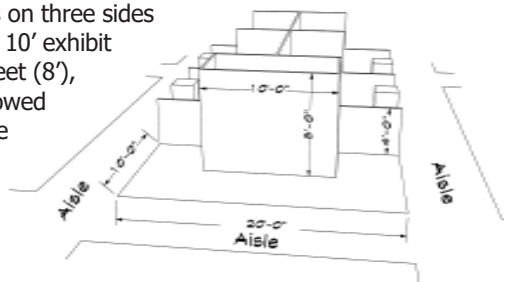

Only gaffers tape can be used to affix any item to the floor. Any exceptions must be approved by TRAC. Damage to the floor will result in charges to the vendor from the TRAC facility.

Exhibition

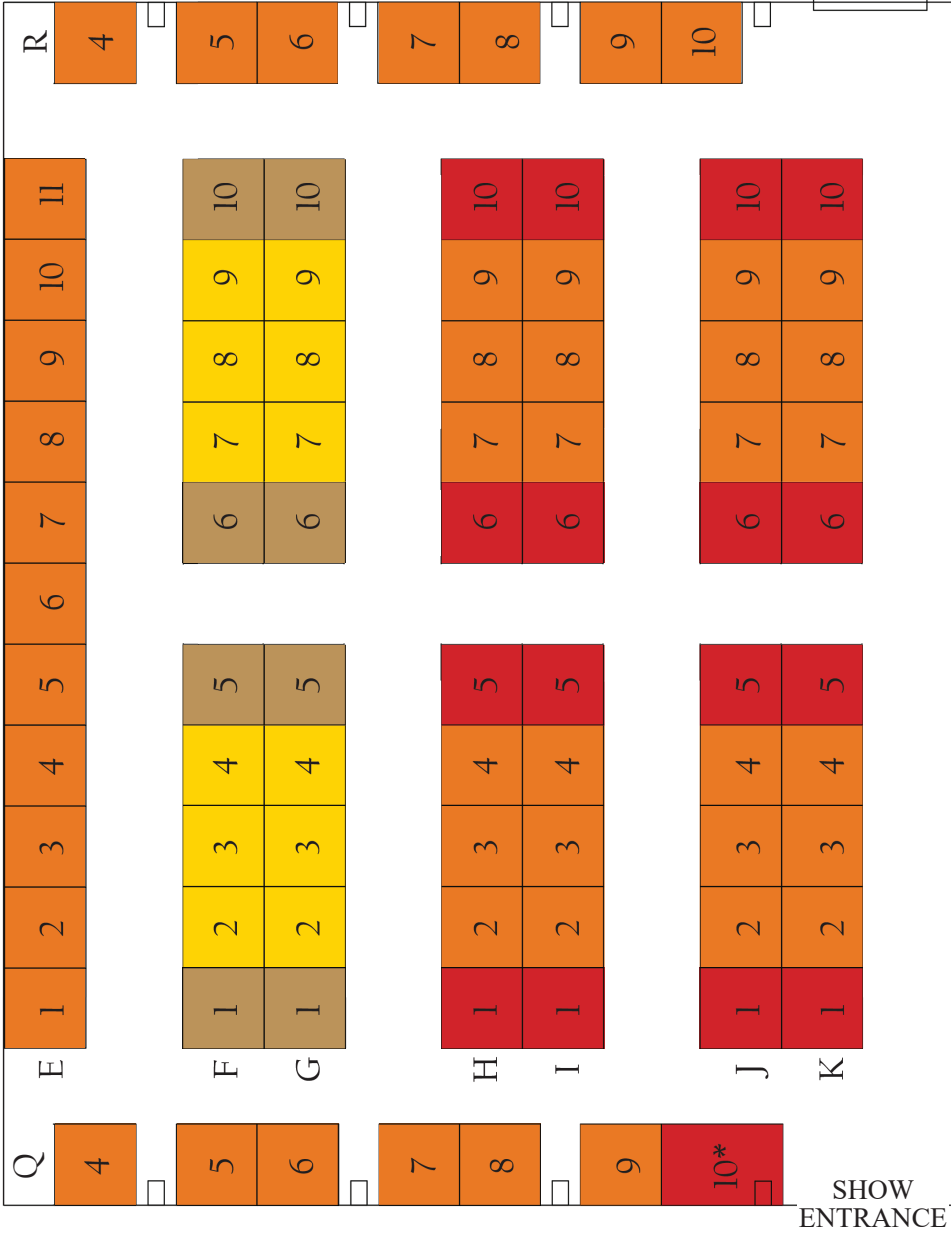

Exhibits located in rows E, H, I, J, K, P, Q or R need not comply with the Exhibit Guidelines e
 These are the only rows wh

*Space Q10 is approximat

Hall Layout

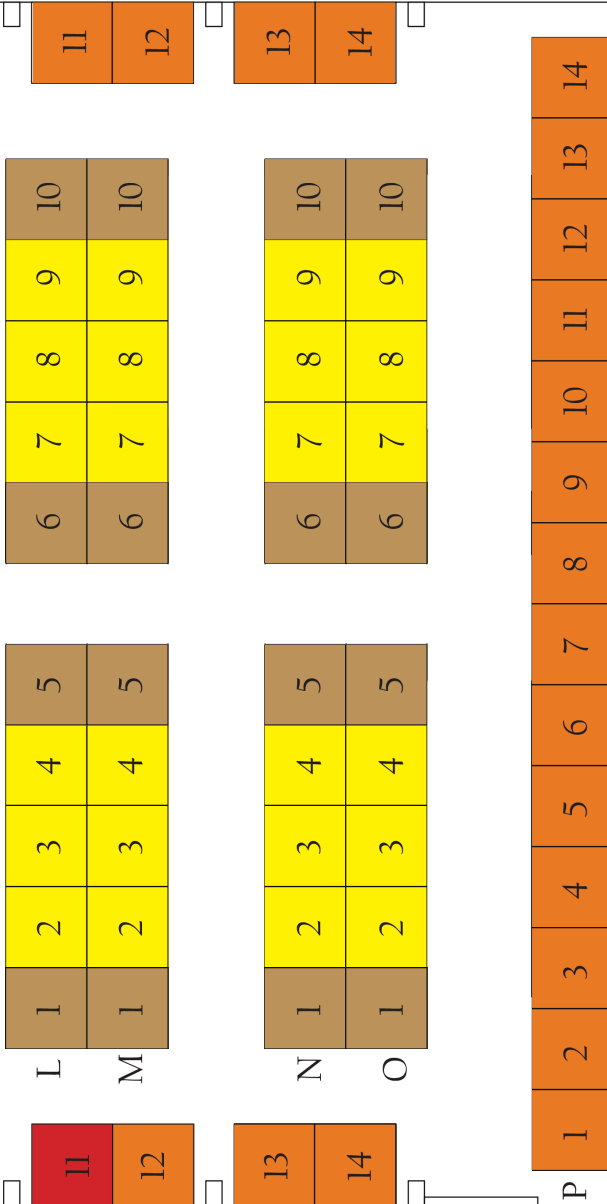

Terms & Conditions

EXHIBIT HOURS - Home Builders Association of Tri-Cities (Management) shall determine and publicize the exhibit hours the Fall Home Show (Show) will be open to the public each day. Exhibitor agrees to have at least one representative at exhibit during all Show hours: Friday - 10 am to 6 pm • Saturday - 10 am to 6 pm • Sunday - 10 am to 4 pm. One representative must check in with TRAC staff at the Exhibitor entrance by 10am each morning or Compliance Deposit will be forfeited.

SET UP - Set up in the Exhibition Hall, Atrium, Entry and Outside exhibit areas begins at 8 am on Thursday, October 3, 2019 unless other arrangements have been made. Other arrangements must be approved by Management and TRAC in advance. Exhibitor shall forfeit his right to the space, all prepaid space costs and upon demand, pay any balance owing Management if he fails to occupy or use his space or to have his exhibit completed and in place by 8 pm on Thursday, October 3, 2019.

DELIVERY - All shipments must be PREPAID by Exhibitor and pre-approved by TRAC. To make arrangements, call TRAC at (509) 543-2999.

SPACE - The contracted space is to be used solely by the Exhibitor whose name appears on the Agreement on this page and no portion can be sublet (i.e., no "sharing" of single exhibit spaces). Except for recognized brand names for which the Exhibitor is a distributor, no other business or company name is allowed to appear in exhibit unless a separate Agreement (accompanied by applicable payment) has been executed with Management for each company. Management has the right to limit the number of exhibit spaces per Exhibitor to fewer than eight. Available space will be assigned on the basis of priority to qualified applicants with products/services not already substantially represented in the Show. PLEASE NOTE: Management reserves the right to deny participation by any applicant who offers goods or services which Management deems inconsistent with the theme of the show. Decisions not to allow participation by an applicant are final. Mere receipt of Agreement by Management does not constitute nor guarantee acceptance of the applicant for participation in the Show.

REASSIGNMENTS - Management shall have the right to move an Exhibitor to another location in order to conform to all city, county, state and federal laws and regulations and the requirements and guidelines of Management or as deemed necessary by Management.

INSTALLATIONS - Any special carpentry, wiring, electrical or other work, steam, water or drainage connections shall be installed at Exhibitor's expense, and in accordance with Management's direction.

ELECTRICITY - Each vendor in the Exhibition Hall and Atrium will be provided with one 120 volt (500 watts/5amps) receptacle at no extra charge.

All electrical needs over and above this amount must be ordered and prepaid through TRAC (Phone: 509.543.2999).

EXHIBITOR PASSES - Three Exhibitor passes are included in exhibit price. Additional Exhibitor passes may be purchased from Management. Exhibitor passes are for the exclusive use of personnel working in exhibits and are not transferable. Exhibitors must use the Exhibitor Entrance and will not be allowed to use any other entrance from Friday until 4 pm on Sunday.

MERCHANDISE REMOVAL / TAKE DOWN - No exhibit, part of an exhibit or merchandise may be removed from Exhibitor's leased space before 4 pm on Sunday unless authorized by Management. Early take down will result in loss of Compliance Deposit and a one year suspension from the show. All exhibit materials and products must be removed from the Exhibition Hall, Atrium and outside exhibit areas by 9 pm on Sunday unless other arrangements have been made. Other arrangements must be approved by Management and TRAC in advance. Management is hereby authorized to remove any and all goods, wares, merchandise and property that remain in these areas after 9 pm on Sunday. Removal of such by management will be at the expense of Exhibitor.

LIABILITY - Exhibitor is entirely responsible for the space occupied by him/her and shall not injure, mar or deface the premises. Exhibitor shall not drive, nor permit to be driven, any pins, nails, hooks, tacks, or screws in any part of the TRAC facility. Furthermore, Exhibitor shall not affix to the walls or windows of the TRAC facility any advertisements, signs, etc., or use adhesive type material on painted surfaces. Automobiles, trucks and similar conveyances shall have a drip pan and/or protective material under them to safeguard the floor. Exhibitor agrees to reimburse Management and/or TRAC for any loss or damage occurring to the premises or equipment.

AISLES - The aisles, passageways, overhead spaces and parking lots remain under the control of Management, and no signs, decorations, banners, advertising matter or exhibits, will be permitted in those areas except by permission of Management. All exhibits and personnel must remain within the confines of their own spaces and no Exhibitor will be permitted to erect signs or display products obstructing the view, occasion injury or disadvantageously affect the display of other Exhibitors, unless exhibit is located in rows E, H, I, J, K, P, Q or R of the Exhibition Hall. (Exhibit Guidelines do not apply in these rows, except that all signs must be one-sided and face inward.)

ALCOHOLIC BEVERAGES - Alcoholic beverages are forbidden in TRAC from set up through take down. A violation shall be grounds for removing Exhibitor and his exhibit from Show without refund.

GENERAL RESTRICTIONS - Exhibitors conducting sales presentations must do so in a manner which assures that Exhibitor personnel and attendees are not encroaching on the aisle or neighboring exhibits. All signage must be one-sided and face inward. Sound equipment (voice amplification devices, speakers, music, etc.) must not be directed into aisles or neighboring exhibits and must be turned off if deemed objectionable by Management. No solicitation or activity can take place outside your physical booth space. Only gaffers tape can be used to affix any item to the floor. Any exceptions must be approved by TRAC. Damage to the floor will result in charges to the vendor from the TRAC facility. Animals (except service dogs) are not allowed in facility during Show hours. Management reserves the right to restrict or remove exhibits without refund, that have been falsely entered or deemed unsuitable or objectionable by Management. This restriction applies to, but is not limited to, noise, sound systems, persons, animals, birds, things, conduct, printed matter, odors, food or anything of a character that might be objectionable to Management.

HEIGHT RESTRICTIONS - The height of booths, display equipment, and signs shall be restricted to the heights indicated in this guide unless written approval of an exception is granted by Management in advance. All Exhibitors have the right to occupy the full cubic content of the contracted exhibit space specified in this guide. All are required to maintain a finished appearance within their booths to a height of eight feet (8'). No wires or studs may be visible. Sides and backs of walls must be finished if visible to public. Booth height is not to exceed eight feet (8') and sign height cannot exceed twelve feet (12') unless exhibit is located in an unlimited row.

RUNNING OF ENGINES - Oil, propane, diesel or gasoline engines cannot be operated inside TRAC.

FORKLIFTS - Forklifts and drivers are not provided by Management. Exhibitors may provide their own forklifts and drivers. The TRAC can provide forklift and driver service, but arrangements must be made in advance and may result in a fee.

CANCELLATION OF CONTRACT - If this Agreement is canceled by Exhibitor for any reason, or by Management because of Exhibitor's default or violation of this Agreement, monies paid to Management by Exhibitor shall be retained as follows: If cancellation occurs on or before September 15, 2019, Management shall retain 100% of the deposit. If cancellation occurs after September 15, 2019 the entire amount paid by Exhibitor shall be retained by Management. The retained monies shall be liquidated for the direct and indirect costs incurred by Management for organizing, setting up and providing space for Exhibitor, and losses and additional expenses caused by Exhibitor's withdrawal including resale of the space. **CANCELLATIONS MUST BE IN WRITING.**

RIGHTS OF MANAGEMENT IN EVENT SHOW IS NOT HELD - Management shall not be liable for any damages or expenses incurred by Exhibitors in the event the Show is delayed, interrupted or not held as scheduled.

SECURITY FOR SPACE PAYMENTS - Failure of Exhibitor to make payments as specified shall entitle Management to take possession of all merchandise, materials and the exhibit displayed by Exhibitor and to retain the same as security for such unpaid amount. Management shall have the right to dispose of same without notice to the Exhibitor in such a manner as it deems appropriate whether by sale or otherwise. Any sale proceeds shall be retained by Management in payment of expenses incurred in disposing of such property and in payment of unpaid amounts.

INDEMNIFICATION - Exhibitor shall indemnify and hold harmless Management and TRAC from and against any and all claims, damages, losses and expenses including attorney's fees arising out of or resulting from the activities of the Exhibitor, or the officers, contractors, licensees, agents, employees, guests, invitees or visitors of Exhibitor.

INSURANCE - Exhibitors desiring insurance upon their exhibits must place same at their own expense. Management will not be responsible for the safety of exhibits against fire, robbery, accident, or any other destructive cause, or for any injury that may arise to the Exhibitors or their employees while in TRAC.

ATTORNEY'S FEES - If a civil action arises between the parties out of this Agreement or to enforce any of its provisions, the losing party shall pay attorney's fees of the prevailing party as the applicable court may adjudge reasonable and if an appeal is taken from any judgment, the losing party shall pay the amount the Appellate Court shall adjudge reasonable as the prevailing party's attorney's fees on appeal. **ALL EXHIBITS MUST COMPLY WITH CITY, COUNTY, STATE AND FEDERAL ORDINANCES, REGULATIONS AND FIRE MARSHAL INSTRUCTIONS. ANY AND ALL CITY, COUNTY, STATE AND FEDERAL LICENSES, INSPECTIONS OR PERMITS REQUIRED BY LAW OF ANY EXHIBITOR IN THE INSTALLATION OR OPERATION OF HIS DISPLAY SHALL BE OBTAINED BY THE EXHIBITOR AT THE EXHIBITOR'S OWN EXPENSE PRIOR TO THE OPENING OF THE SHOW. EXHIBITOR SHALL REIMBURSE MANAGEMENT FOR ANY COSTS ASSOCIATED WITH EXHIBITOR'S FAILURE TO OBTAIN APPLICABLE LICENSING AND/OR PERMITS OR FAILURE TO COMPLY WITH APPLICABLE REGULATIONS.**

Agreement

NO EXHIBITOR WILL BE PERMITTED TO PARTICIPATE WITHOUT PAYMENT IN FULL ACCORDING TO THIS AGREEMENT. FAILURE OF EXHIBITOR TO MAKE PAYMENT AS SPECIFIED SHALL ENTITLE THE HOME BUILDERS ASSOCIATION OF TRI-CITIES (MANAGEMENT), AT ITS OPTION, TO CANCEL THIS AGREEMENT WITHOUT NOTICE AND EXHIBITOR SHALL REMAIN LIABLE FOR ANY UNPAID BALANCE. BOOTHS WILL NOT BE HELD UNTIL A SIGNED AGREEMENT AND DEPOSIT ARE PROVIDED TO THE MANAGEMENT.

Each exhibit space is approximately ten feet by ten feet (10' x 10'), with side rails approximately three feet (3') from the floor with eight foot (8') tall rear panels. Exhibitors are required to follow the Exhibit Guidelines in this brochure unless exhibit is located in rows E, H, I, J, K, P, Q or R or unless specific, written approval to deviate has been received from Management prior to set up. The location of your exhibit space(s) is/are subject to assignment by Management. Upon acceptance of this Agreement by Management, Agreement shall become a binding and enforceable contract between the parties.

A \$100 Compliance Deposit is required of all exhibitors. Should an exhibitor fail to follow the terms and conditions on the previous page, the exhibitor will forfeit the full \$100 amount. Compliant exhibitors will receive a full refund or account credit of the deposit within 90 days of the Show's conclusion.

Use of the name "HBA", "Fall Home Show" or that of any office of said organization in recommendations of a product or service is expressly prohibited. The Terms and Conditions on the previous page are part of this Agreement.

IT IS AGREED: Subject to the Terms and Conditions on the previous page, which are incorporated in and are part of this Agreement, and upon acceptance of the Agreement by Management, the undersigned (Exhibitor), agrees to reserve from Management the number of exhibit spaces stated below for the duration of the 2019 Fall Home Show.

Company Name _____
(for signs & advertising)

Contact _____

Mailing Address _____

City/State/ZIP _____

Phone _____ Email _____

I would prefer to receive my Vendor Info Packet via: Mail Email

UBI/Washington Registration Number (required by law) _ _ _ _ - _ _ _ _ - _ _ _ _ (i.e. 601-555-555)

Type of merchandise or service provided: _____

Exhibit location preference: _____
(Subject to assignment by Management): 1st Choice 2nd Choice 3rd Choice

- A. Exhibit Prices
- 1. Number of Linear Exhibit spaces: _____ @ \$500 each = \$ _____
 - 2. Number of Unlimited Linear Exhibit spaces: _____ @ \$500 each = \$ _____
 - 3. Number of Corner spaces: _____ @ \$600 each = \$ _____
 - 4. Number of Vehicle/Outdoor spaces: _____ @ \$250 each _____ @ \$500 each = \$ _____

B. Compliance Deposit (REQUIRED) \$ _____ **\$100**

C. Total Exhibit Prices (Add all under A + B) \$ _____

D. Less Early Bird Discount _____ @ \$50 each = \$ _____
(Agreement & Deposit must be received by July 31, 2019 to qualify)

E. Less HBA Member Discount:
\$100 per each exhibit space if you are a current member of
Home Builders Association of Tri-Cities as of Oct. 2019 _____ @ \$100 each = \$ _____

F. Deposit Enclosed With This Agreement (\$100/first exhibit space; \$50/additional) \$ _____

G. Remaining Balance Due by September 1, 2019 (C minus D, E and F) \$ _____
Balances owed after September 1, 2019 will be subject to a \$50 late payment fee
Booths with balances owed after September 15, 2019 are subject to cancellation

Exhibitor Signature

Show Management

Make checks payable to: **HBA of Tri-Cities** • (\$30 charge for returned checks)

Paying by credit card? Call the HBA at (509) 735-2745.

Mail AGREEMENT with payment to: Home Builders Association, 10001 W. Clearwater Ave, Kennewick, WA 99336

Fax to 509.735.8470 • Email heather@hbatc.com



Home Builders Association of Tri-Cities
10001 W Clearwater Ave
Kennewick, WA 99336
(509) 735-2745

PRSRT STD
U.S. POSTAGE
PAID
RICHLAND, WA
PERMIT NO. 97